



HRE-0300-4 HEAT REACTIVATED DESICCANT AIR DRYER GENERAL ARRANGEMENT

TOLERANCES UNLESS
OTHERWISE SPECIFIED:

- FRACTIONS = ± 1/4 "
- ANGLES = ± 3°
- INCHES = ± 1/2 "
- FINISH = 250

THE SPECIFICATIONS AND DRAWINGS DISCLOSED HEREIN ARE THE SOLE PROPERTY OF ALTEC AIR, AND SHALL NOT BE COPIED OR USED AS THE BASIS FOR SALE OR MANUFACTURE WITHOUT EXPRESS WRITTEN PERMISSION.

REVISION LOG

REV.	ECO.	DESCRIPTION	DATE	APPROVED
C	1093	INCREASED CENTER TO CENTER LENGTH	2/8/2021	WS

DRAWING NO.

AT20-947

REV.
C

DRAWN: WS

DATE: 2/16/2017

CHECKED:

DATE:

SCALE: N/A

SHEET: 1 OF 2

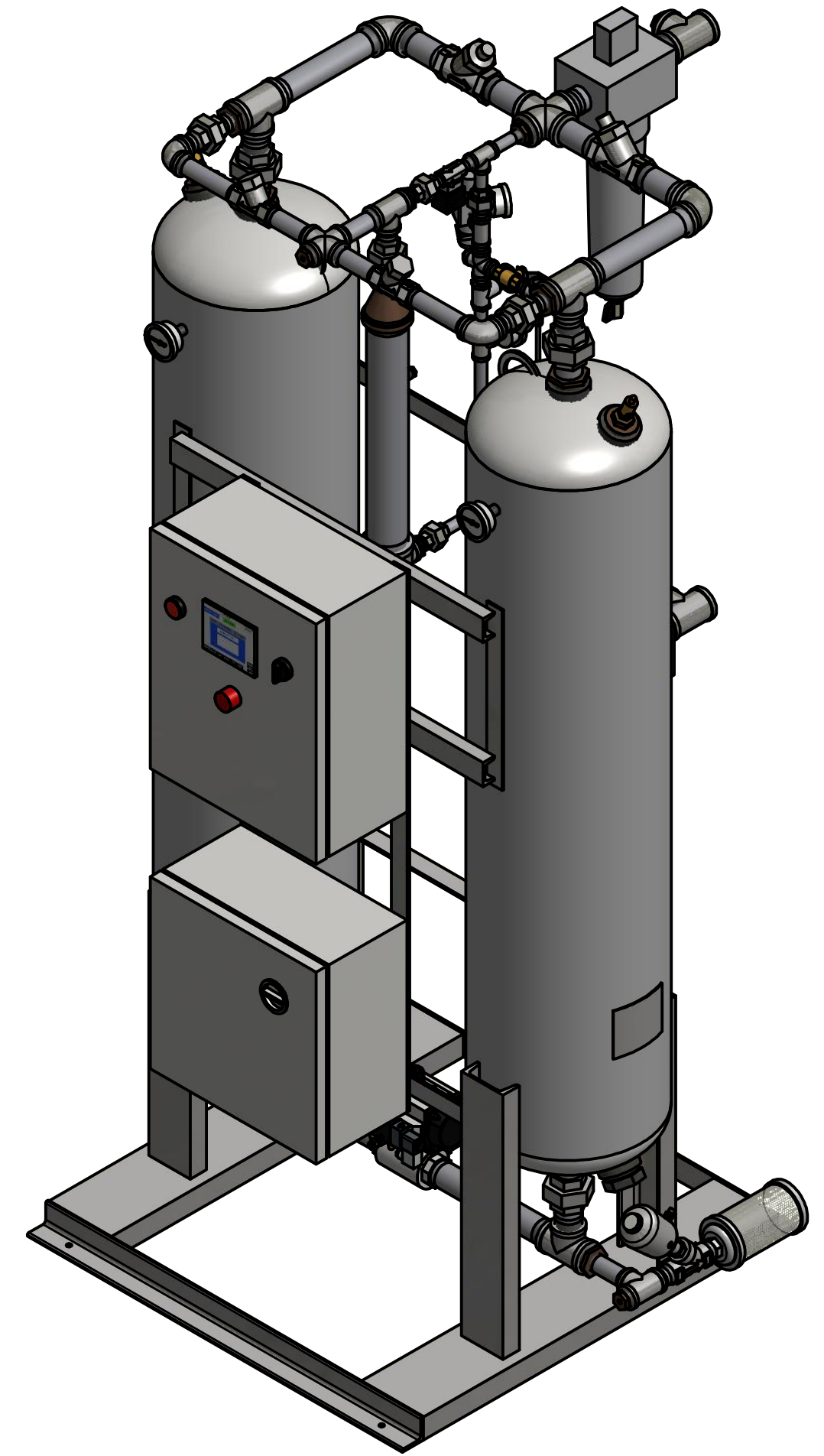
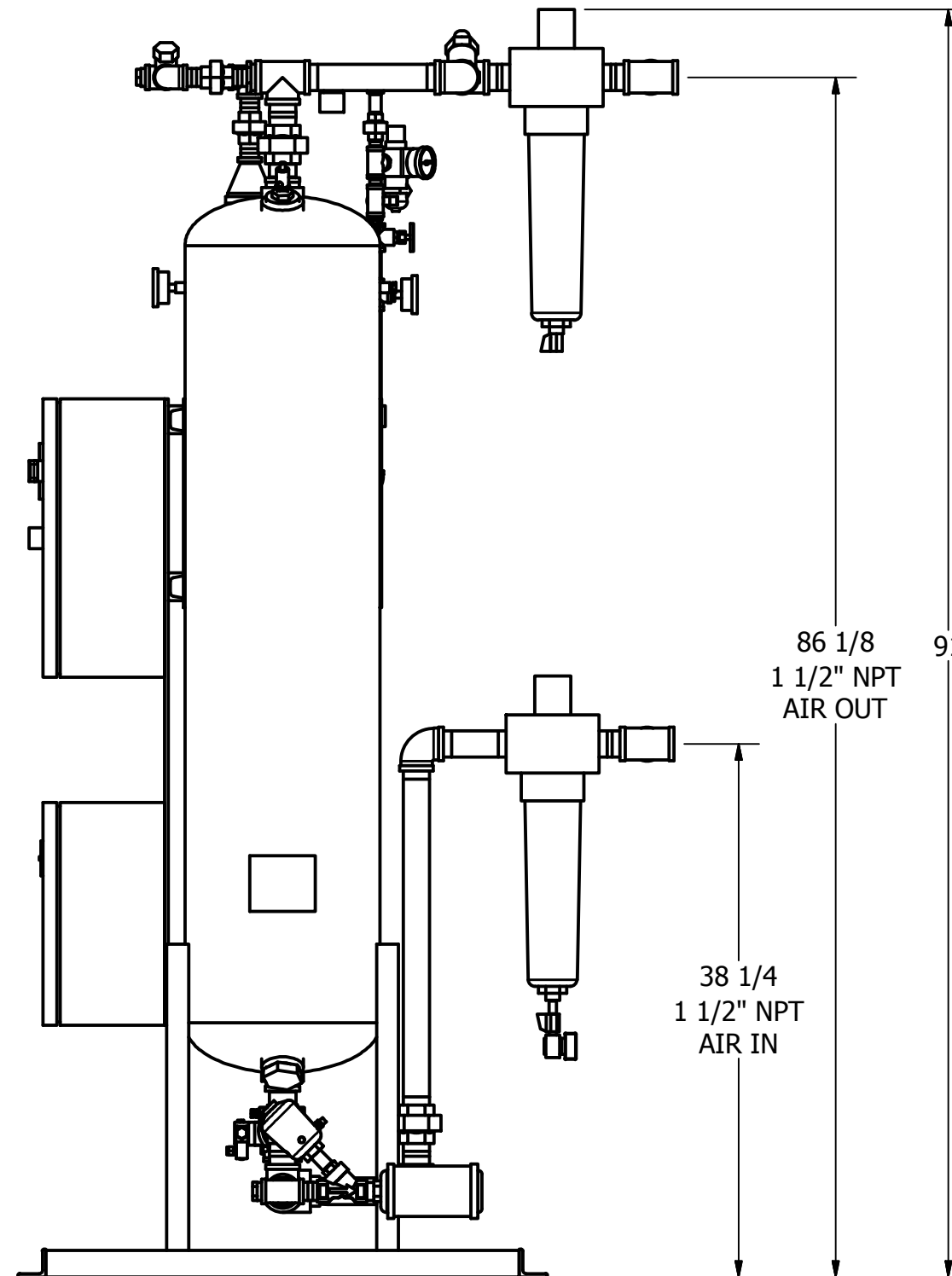
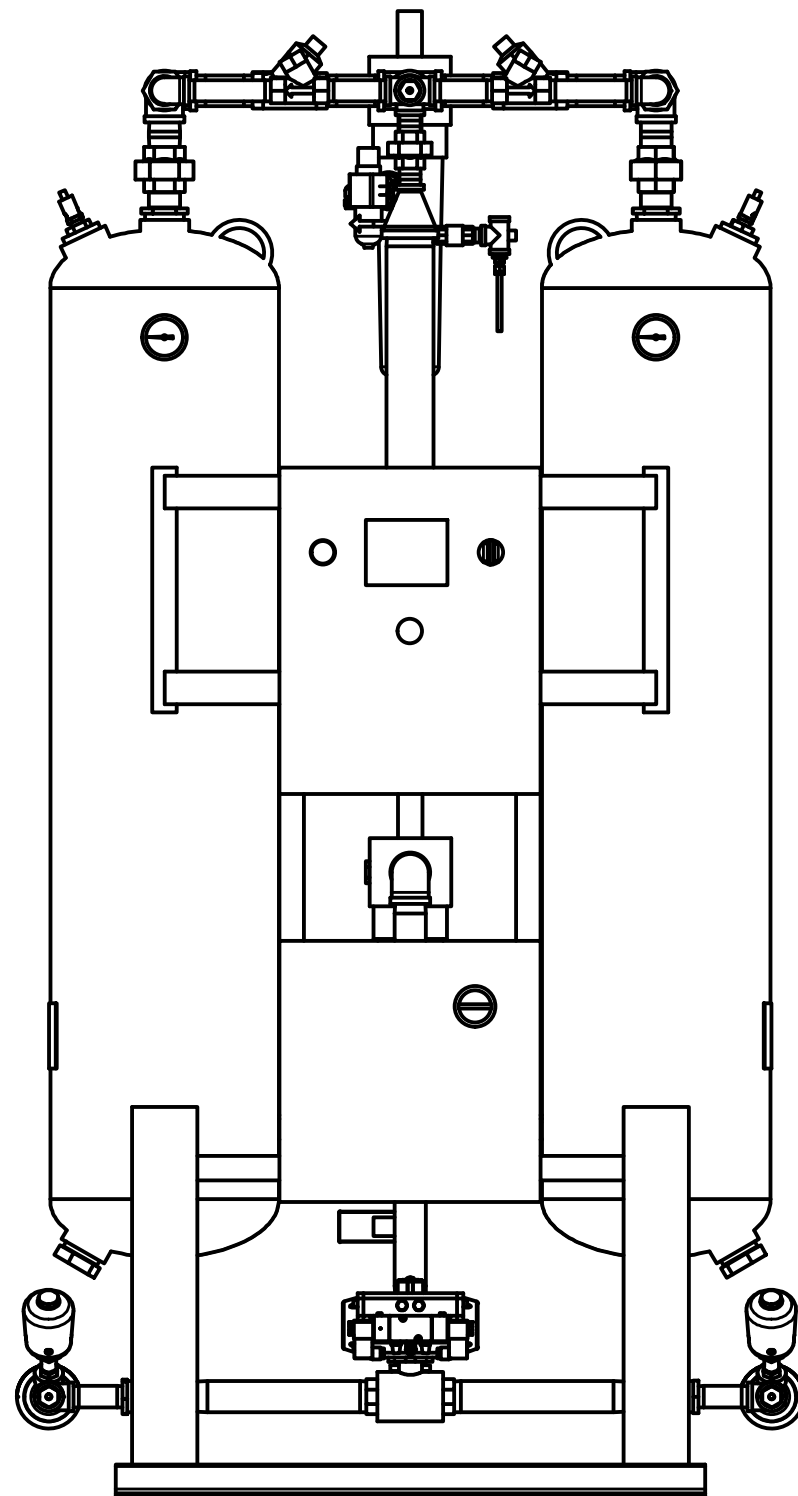
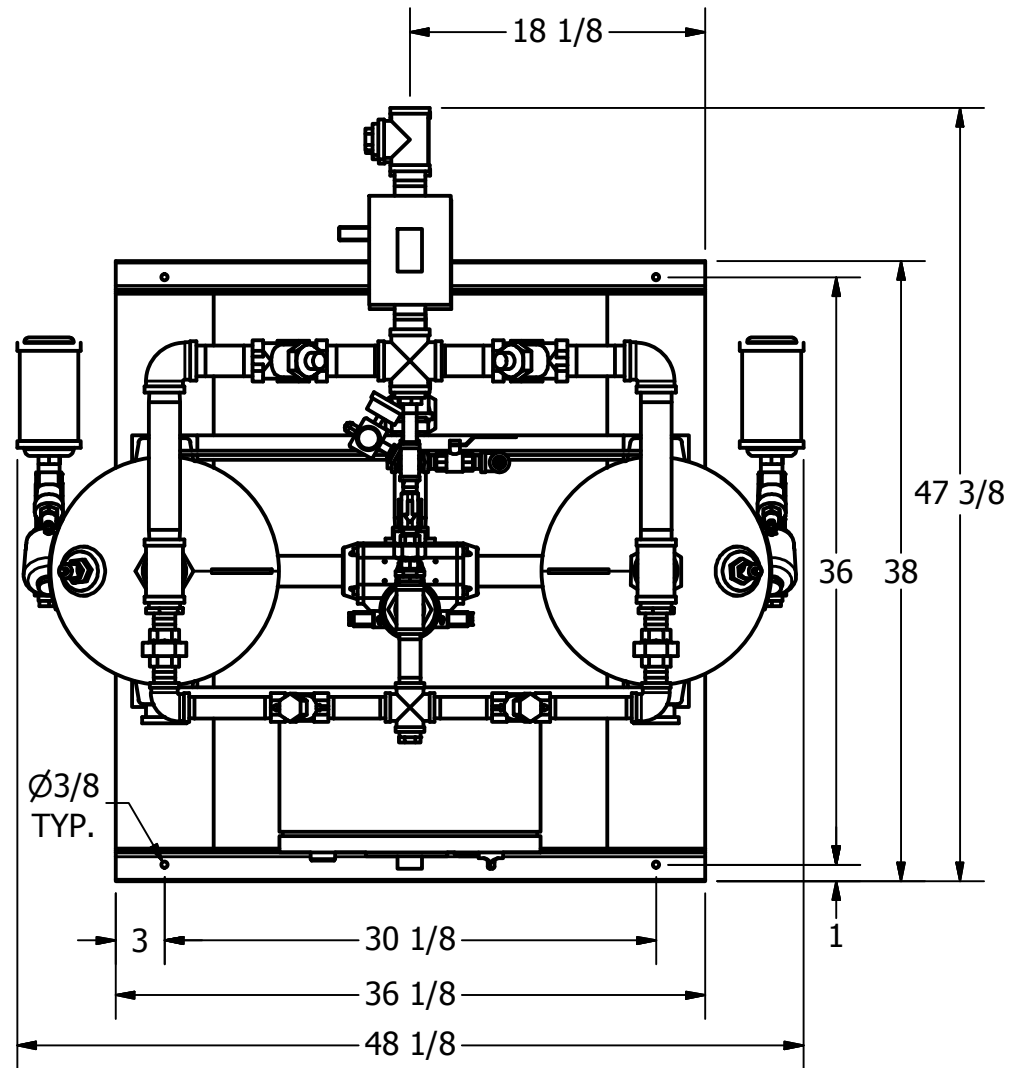

PRELIMINARY



HRE-0300-4 HEAT REACTIVATED DESICCANT AIR DRYER GENERAL ARRANGEMENT

TOLERANCES UNLESS OTHERWISE SPECIFIED:

FRACTIONS = ± 1/4 "
 ANGLES = ± 3°
 INCHES = ± 1/2 "
 FINISH = 250

THE SPECIFICATIONS AND DRAWINGS DISCLOSED HEREIN ARE THE SOLE PROPERTY OF ALTEC AIR, AND SHALL NOT BE COPIED OR USED AS THE BASIS FOR SALE OR MANUFACTURE WITHOUT EXPRESS WRITTEN PERMISSION.

REVISION LOG

REV.	ECO.	DESCRIPTION	DATE	APPROVED
C	1093	INCREASED CENTER TO CENTER LENGTH	2/8/2021	WS

DRAWING NO.

AT20-947

REV.
C

DRAWN: WS
 CHECKED:
 DATE: 2/16/2017
 DATE:

SCALE: N/A
 SHEET: 2 OF 2

PARTS LIST

ITEM	QTY	DESCRIPTION
1	2	CHECK VALVE, PURGE
2	1	SOLENOID VALVE, REPRESS
3	2	CHECK VALVE, OUTLET
4	1	PARTICULATE AFTER-FILTER
5	1	GATE VALVE, PURGE
6	1	PRESSURE GAUGE, PURGE
7	1	PRESSURE REGULATOR, CONTROL
8	1	PRESSURE GAUGE, CONTROL
9	1	DEW POINT MONITOR (OPTIONAL)
10	2	RELIEF VALVE, TANK
11	2	PRESSURE GAUGE, TANK
12	1	3 KW HEATER
13	1	3-WAY BALL VALVE, INLET
14	1	COALESCER PRE-FILTER
15	1	TIMED DRAIN
16	2	ANGLE BODY VALVE, EXHAUST
17	2	MUFFLER, EXHAUST
18	420 LBS	DESICCANT

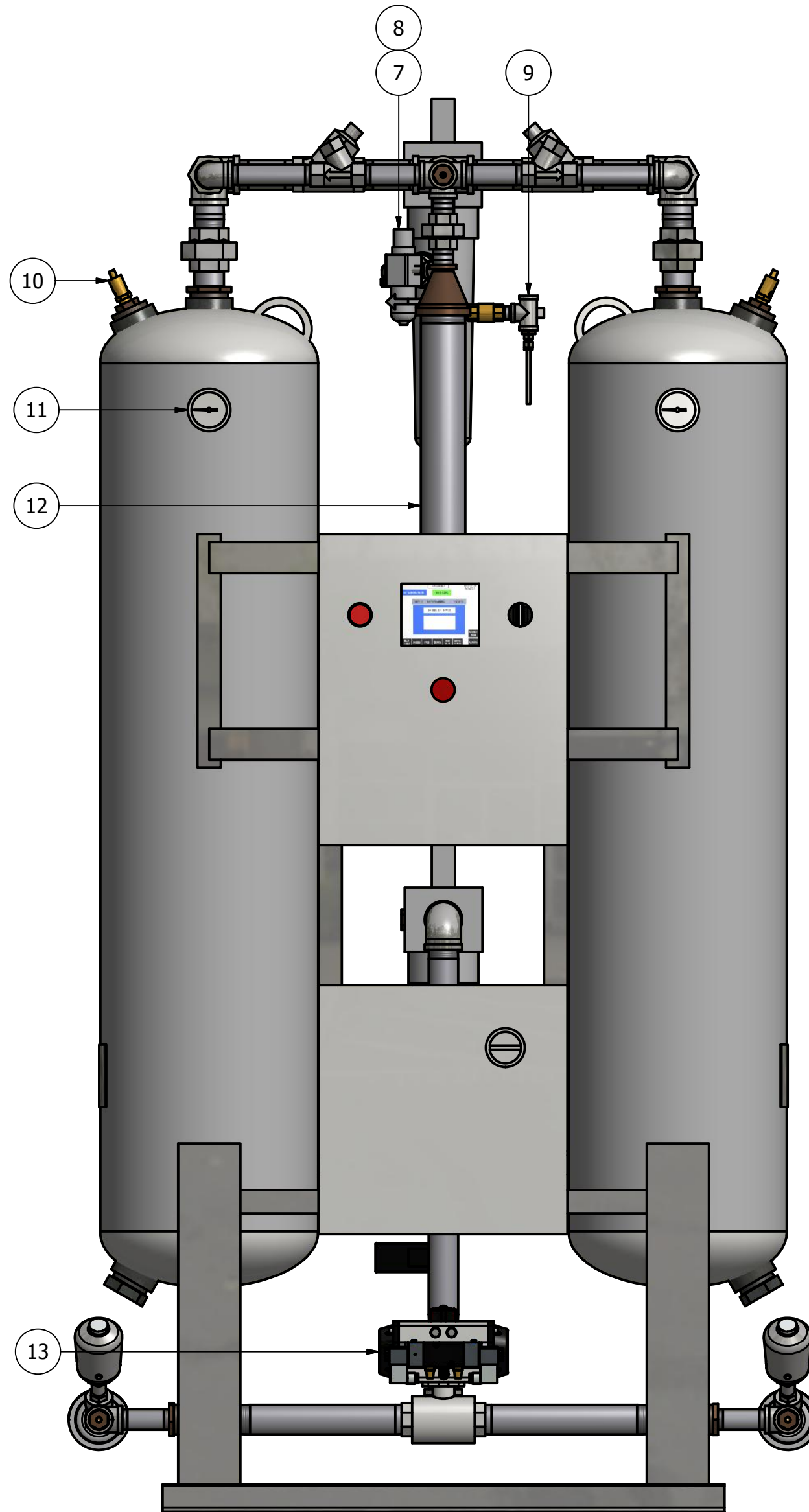
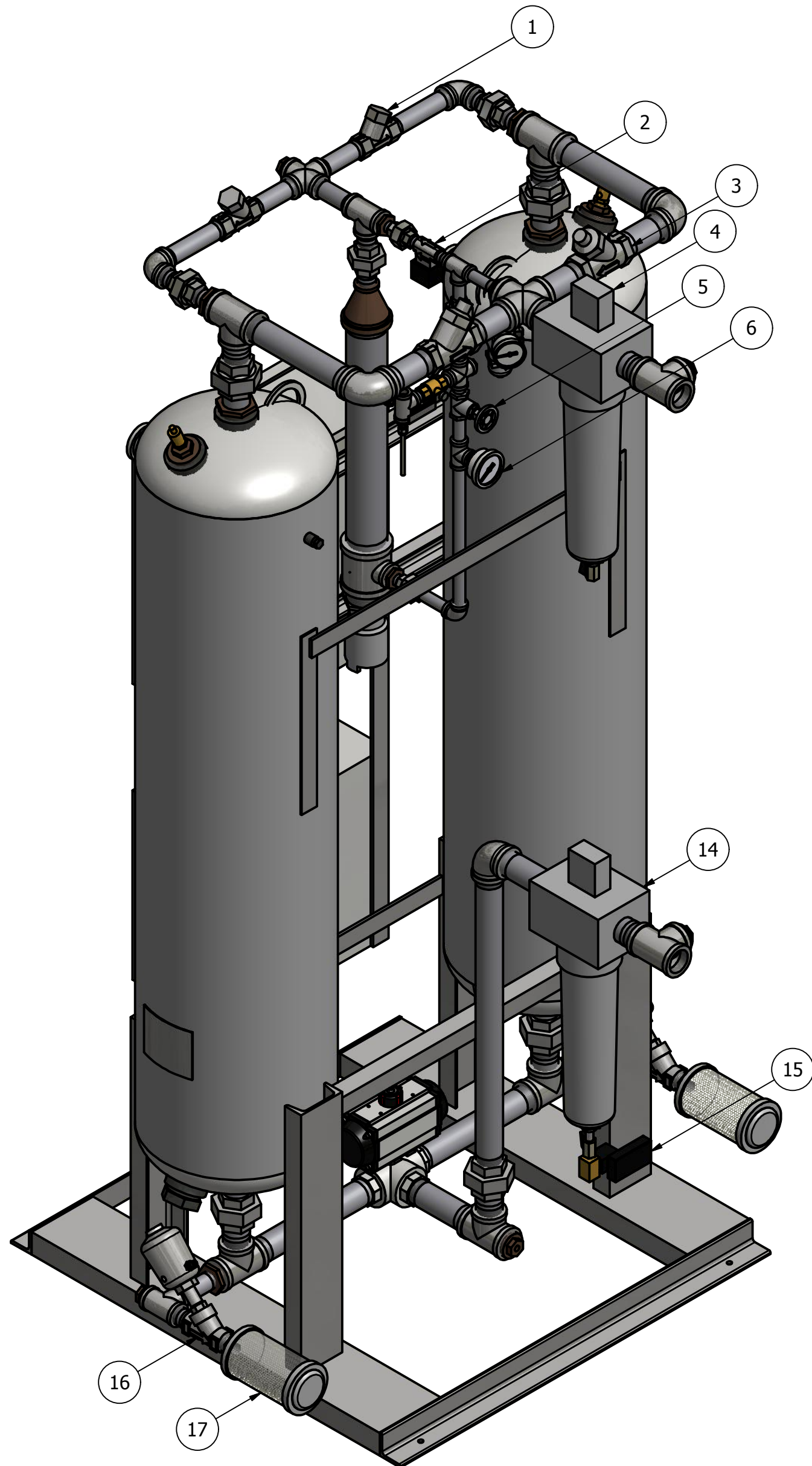

PRELIMINARY